

Power supplies for cold cathode lamps.

Via Caravaggio 26 20033 Desio MI

tel. ++39 0362 630872 (a.r.) fax.+++ 620489

DATA SHEET neon convertor Type MIDI ECG 900-180

- Available in the following versions: *Standard, Dimmer(built in), Flasher(built in), Remote control, Remote dimmer (0-10v Standard)*
- Compliant with standard EN 61347-2-10 for the **L.V. Directive**
- Compliant with standard EN 61000-3-2, EN 55015 3rd ed., EN 61547 for the **EMC Directive**
- **Type B** converter in accordance with EN 61347-2-10 (protection against secondary ground fault leakage is required)
- 230v. input, with Italian or Schuko plug and a 1,5m cable.
- Output with 1m cable type **K** (as per EN 50143). Insulation in polyethylene and PVC. External diameter 4,5mm. Section 1mm²

Electrical data:

Input :	Voltage	Volt 200 - 250
	Current	Ampere 0,35 (at 230v)
	Frequency	Hertz 50/60
	Power	Watt 85
	Power factor	$\lambda > 0.98$
Input control :	Remote control flasher	0 volt= on 5...10 volt DC(10mA)=off
	Remote dimmer	0 volt=minimum light 10 volt=maximum light
	(without any connections on remote wire the light is maximum)	
Output:	Voltage	Volt 499 – E – 499V rms maximum
	Nominal load current	mA 170
	Short circuit current	mA 200
	Frequency	Hertz 24.000

Performances:

- These power supplies are not compatible with any type of in-line flashers or dimmers.
- For dimming and flashing applications, remote dimmer or remote control converter model must be used.
- Suitable both for lamps loaded with argon + mercury gas as well as with 100% neon gas (lack of "bubble" effect and of mercury migration)
- Supplied with **open circuit protection, ground fault protection and protection against overloading**
- Maximum ambient temperature 40 c°
- Place 10mm far from metal surfaces

Loading: maximum one lamp.

Length: as per the here below mentioned chart.

	d.15mm	d.18mm	d.20mm	d.25mm
Argon	mt. 1,6	mt. 1,9	mt. 2,0	mt. 2,3

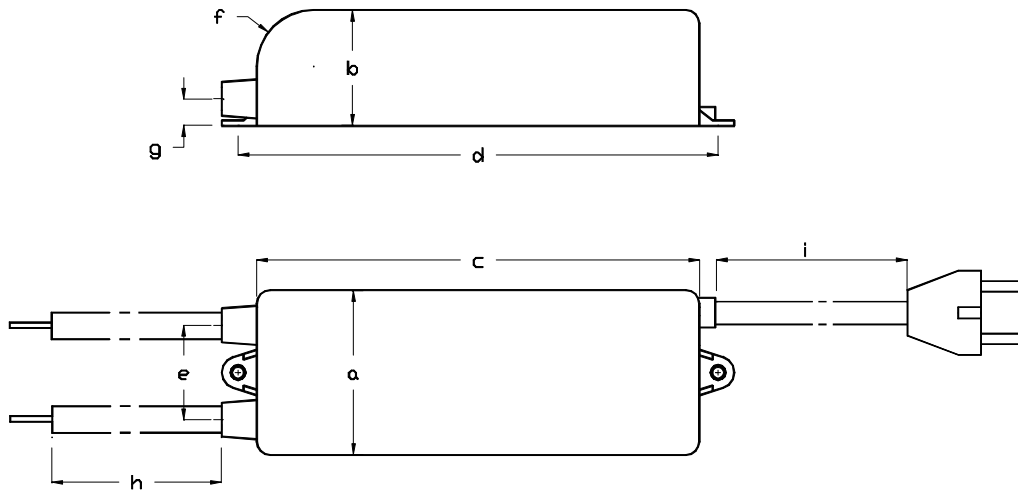

	a	b	c	d	e	f	g	h	i	weight
MIDI	48	35	150	162	25	14	6	1000	1500	650 g

All dimensions are in mm.

INSTALLATION GUIDELINE

- For high voltage connections use the cable connected to the transformer with no further additions.
- The converter must be, on all its' sides, **1 cm apart** from the metal surface.
- The converters must be at least **2 cm far** from one another.
- The distance between the lamps and parts with different potential (other lamps, current conductors, parts connected to earth) shall be suitable to the voltages on site which, at the frequencies produced by the converter, can discharge easily through air and unsuitable insulating material.
- The material of the supports of the lamps must be always insulating (EN 50107)
- To comply with the *electromagnetic compatibility* directive (EMC), from the output of the converter to the feeding supply, **avoid placing the feeding cable near the neon lamps and/or the high voltage cables.**

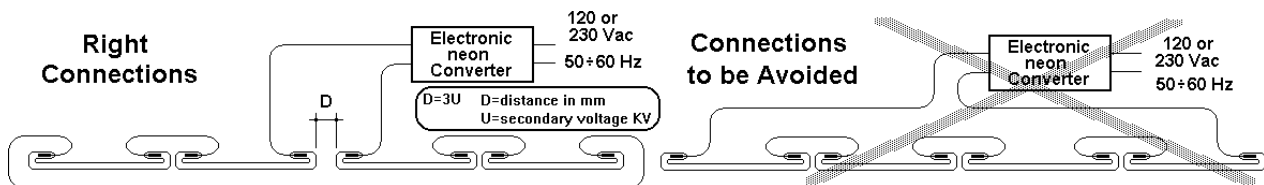

Electronica per luce s.r.l.

Via Caravaggio 26 - 20033 Desio (MI) - Italy - tel. +39 (0)362 630872 (a.r.) fax.+++ 620489

TECNOLUX
GROUP