

Power supplies for cold cathode lamps.

Via Caravaggio 26 20033 Desio MI

tel. ++39 0362 630872 (a.r.) fax.+++ 620489

update: no. 1

DATA SHEET neon convertor Type MAXI 9020 k

- Available in the following versions: *Standard, Dimmer, Flasher, Remote control*
- Compliant with standard EN 61347-2-10 for the **L.V. Directive**
- Compliant with standard EN 61000-3-2, EN 55015 3rd ed., EN 61547 for the **EMC Directive**
- **Type B** convertor in accordance with EN 61347-2-10 (protection against secondary ground fault leakage is required)
- 230v. input, with Italian or Schuko plug and a 1,5m cable.
- Output with 1m cable type **B** (as per EN 50143). Insulation in silicon. External diameter 6,3mm. Section 1mm²

Electrical data:

Input :	Voltage	Volt 230
	Current	Ampere 0,35 maximum
	Frequency	Hertz 50/60
	Power	Watt 80 maximum
	Power factor	$\lambda > 0.95$

Output:	Voltage	Volt 4.5 KV – E – 4.5KV rms maximum
	Nominal load current	mA 20
	Short circuit current	mA 25
	Frequency	Hertz 24.000

Performances:

- In compliance with *Flashers (0.5sec. delay at switching on)*
- Not compliant with *Dimmers*
- Suitable both for lamps loaded with argon + mercury gas as well as with 100% neon gas (lack of “bubble” effect and of mercury migration)
- Supplied with **open circuit protection, ground fault protection and protection against overloading**
- Maximum ambient temperature 40 c°
- Place 10mm far from metal surfaces

Indicative chart of maximum loading for electronic converters

For every electrode couple 50cm must be calculated.

	d.6mm	d.8mm	d.10mm	d.12mm	d.15mm	d.18mm	d.20mm
Argon	mt 8,6	mt 9,8	mt. 11	mt. 12	mt. 13	mt. 14	mt. 15
Neon	mt. 5,8	mt. 7	mt. 8	mt. 8,6	mt. 9,3	mt. 10	mt. 11

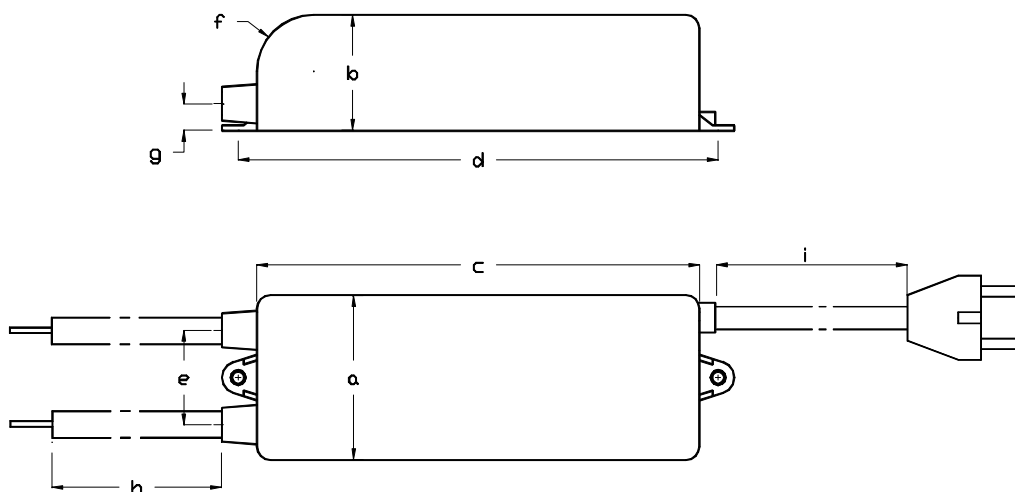

	a	b	c	d	e	f	g	h	i	weight
MAXI	59	46	163	178	35	21	10	1000	1500	1.100 g

All dimensions are in mm.

INSTALLATION GUIDELINE

- To verify that the converter is not overloaded add to the lamps to be lit a 40 K Ω (11 watt) resistor. If tripping occurs, reduce the number of lamps to feed. To check for presence of installation problems, this test shall be performed when sign is finished.
- For high voltage connections use the cable connected to the transformer with no further additions.
- The converter must be, on all its' sides, **1 cm apart** from the metal surface.
- The converters must be at least **2 cm far** from one another.
- The distance between the lamps and parts with different potential (other lamps, current conductors, parts connected to earth) shall be suitable to the voltages on site which, at the frequencies produced by the converter, can discharge easily through air and unsuitable insulating material.
- The material of the supports of the lamps must be always insulating (EN 50107)
- To comply with the *electromagnetic compatibility* directive (EMC), from the output of the converter to the feeding supply, **avoid placing the feeding cable near the neon lamps and/or the high voltage cables.**

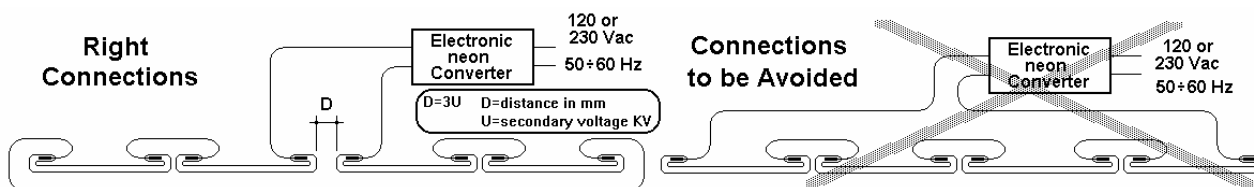

Electronica per luce s.r.l.

Via Caravaggio 26 - 20033 Desio (MI) - Italy - tel. +39 (0)362 630872 (a.r.) fax.+++ 620489

TECNOLUX
GROUP